

SERIES 8400 OPTALARM™ USER'S MANUAL

This manual has been developed by the Key Instruments and is intended for the use of its customers and service personnel. The information in the manual is subject to change without notice. While every effort has been made to eliminate errors, Key Instruments disclaims liability for any difficulties arising from the interpretation of the information contained herein.

**For Technical Customer Support
Service please call 1.800.356.7483**

Printed in U.S.A.
11/05
IDT158 Rev. 004



KEY INSTRUMENTS

1.800.356.7483

www.keyinstruments.com

WARRANTY

The Seller warrants all parts will be free from defects in workmanship or material under normal use and service for a period of one year from date of shipment. Liability under this warranty is limited to repair or replacement, F.O.B. factory, of any parts which prove to be defective within that time or repayment of the purchase price at the Seller's option provided the products have been returned, transportation prepaid, within one year from date of purchase. Product recommendations are based on data and information, which the Seller believes to be correct, and are intended for use by individuals having knowledge and expertise as to their application. Seller is not liable beyond replacement of equipment, F.O.B. factory, or the full purchase price. This warranty is void if the instrument or equipment is abused, altered, used at ratings above the specified maximum or is misused in any way.

THIS EXPRESSED LIMITED WARRANTY EXCLUDES ALL OTHER REPRESENTATIONS MADE BY ADVERTISEMENTS OR BY AGENTS AND ALL OTHER WARRANTIES, BOTH EXPRESS AND IMPLIED. THERE ARE NO IMPLIED WARRANTIES OF MERCHANTABILITY OR OF FITNESS FOR A PARTICULAR PURPOSE FOR GOODS COVERED HEREUNDER.

Power Requirements

- Wall Transformer Power Supply- 12 VDC @ 500 mA

Table of Contents

Connector and pin-out description

- The Optalarm™ is provided with a female 8 position Mini-DIN connector for output signal acquisition. The pin configuration for the connector is as follows:

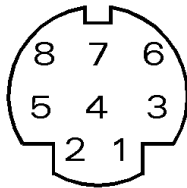

Figure 5: 8-Pin Mini-DIN as seen from side of Optalarm™

- A pre-assembled single ended cable assembly (pigtail) is available to interface the Optalarm™ outputs to an external alarm. (Part No. ELA001)

DESCRIPTION	1
IDENTIFICATION OF COMPONENTS	2
FEATURES	3
OPERATION	5
CLEANING THE FLOW TUBE	7
SPECIFICATIONS	9

PIN NUMBER	UNPOWERED STATE OR ALARM CONDITION	POWERED STATE (OPERATING STATE)	WIRE COLOR
1	Ground	Ground	Brown
2	LOW Limit Dry Contact, Open	LOW Limit Dry Contact, Closed	Red
3	LOW Limit Dry Contact, Common	LOW Limit Dry Contact, Common	Orange
4	External DC Power, (+)	External DC Power, (+)	Yellow
5	HI Limit Dry Contact, Closed	HI Limit Dry Contact, Open	Green
6	HI Limit Dry Contact, Common	HI Limit Dry Contact, Common	Blue
7	LOW Limit Dry Contact, Closed	LOW Limit Dry Contact, Open	Purple
8	HI Limit Dry Contact, Open	HI Limit Dry Contact, Closed	Black

CLEANING THE FLOW TUBE

Occasional cleaning may be required if dirt appears in the **flow tube** or if float movement becomes restricted. Turn unit off and disconnect the power supply. **(Do not allow any liquids to enter the electronics.)** *Bleed off any pressure* in the flowmeter and disconnect the flowmeter from the system to ensure safety. Next, remove the **lens cover** (Figure 4, 1) by removing the four **screws** (Figure 4, 2) located at the top and bottom of the cover. With a 5/32" Allen wrench, turn the **jackscREW** (Figure 4, 7) counter-clockwise until it reaches a stop. Gently remove the **flow tube** (Figure 4, 3) from the frame.

Using extreme care, remove the **top and bottom float stops** (Figure 4, 5 and 10) and remove the float. Clean the **tube** with a mild liquid detergent and a soft brush or swab. Rinse / flush with clean water and dry thoroughly with clean, dry air or nitrogen. Make sure that all of the parts are thoroughly cleaned and dry. Re-install parts as follows: **bottom float stop** (the longer of the two float stops) from bottom of glass tube, **ball float** (Figure 4, 4) and **top float stop**. Check the **top and bottom gasket** (Figure 4, 6) and replace if necessary. Reposition the **gaskets** into the block and carefully reinsert the **flow tube** into the meter frame. Be sure that the tube is properly positioned with the scale facing forward. Gently press against the **tube alignment guides** (Figure 4, 9) until they are tight against the back of the meter frame.

Tighten the **jackscREW** by turning clockwise with the Allen wrench until the gaskets make contact with the tube. Carefully tighten $\frac{1}{2}$ - $\frac{3}{4}$ turn more or torque to 1-1.75 in-lbs. to achieve a positive seal. **Do not over-tighten.** If any liquid enters the electronics, be sure unit is thoroughly dry before reconnecting power cord. Finally, replace the **lens cover** onto the meter, secure it properly, and then reconnect the meter back into the flow loop.

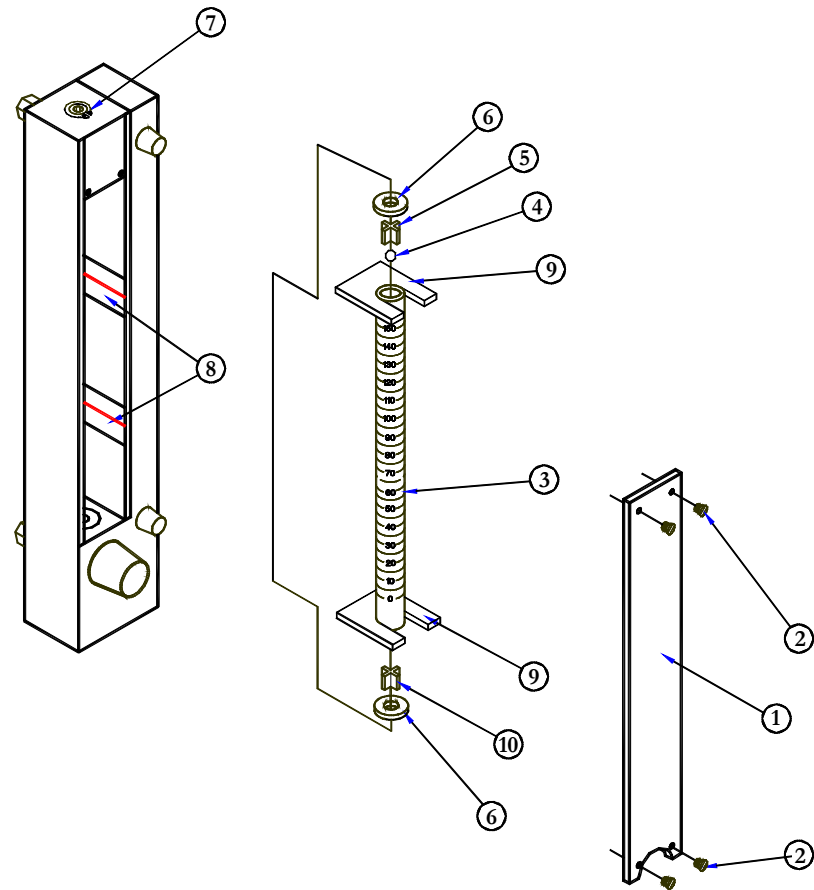

NUMBER	DESCRIPTION
1	Lens Cover
2	Lens Cover Screws
3	Flow Tube
4	Ball Float
5	Top Float Stop
6	Top and Bottom Gaskets
7	Jackscrew
8	Upper and Lower Sensors
9	Tube Alignment Guides
10	Bottom Float Stop

Figure 4 – Flowmeter Assembly

DESCRIPTION

The Optalarm™ is a flow-monitoring device that allows the user to set gas or liquid flow parameters. Any deviation from the preset flow parameters is indicated by the appropriate flashing LED and by a 90-dB audible signal. The 8 Pin Mini-DIN Connector can also be used to drive external sirens and switches, and also to supply power to the unit.

The Upper and Lower Sensors continuously monitor the flow parameters, which have been selected from the supplied Flow Curve and Correlation Data. To operate the unit, use the Set-Point Adjustment Knobs (Figure 1, 1) to adjust the Upper and Lower Sensors (Figure 1, 2) to the predetermined flow points. The valve is then opened until an acceptable flowrate is obtained. Once the flowrate has been set, the On/Off Reset button (Figure 1, 3) is used to select the operation mode and begin monitoring. The instrument is capable of detecting a float moving at speeds up to 400 ft/second.

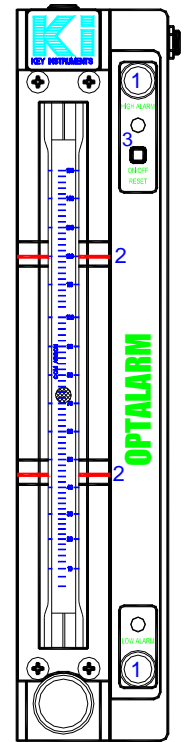
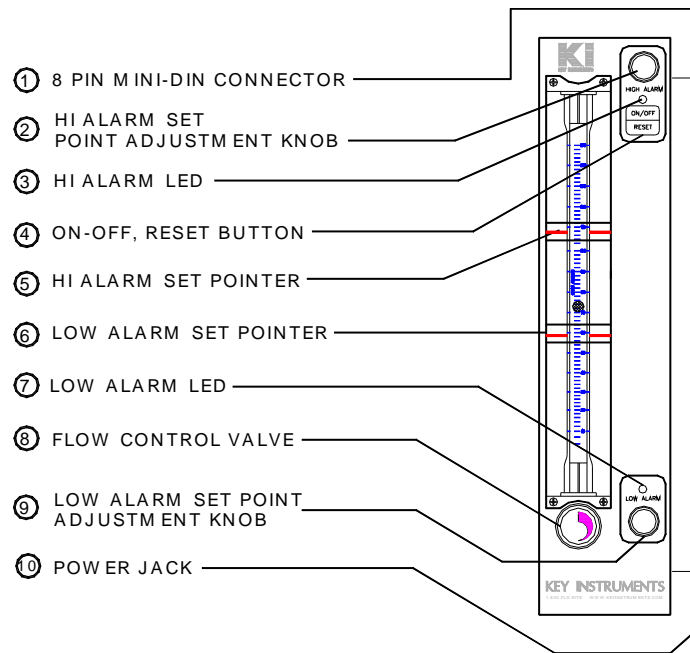

Figure 1

IDENTIFICATION OF COMPONENTS



NUMBER	NAME	FUNCTION
1	8 Pin Mini-DIN Connector	Used for Remote Data Acquisition
2	HI Alarm Adjustment Knob	Used to Position HIGH Alarm Set Point
3	HI Alarm LED	Turns on in Steady State at Start-up; Flashes when HI Alarm is Tripped
4	ON-OFF, Reset Button	Used to Toggle through Operating Modes
5	HI Alarm Set Pointer	Indicates Point on Scale for which HI Alarm will sound
6	LOW Alarm Set Pointer	Indicates Point on Scale for which LOW Alarm will sound
7	LOW Alarm LED	Turns on in Steady State at Start-up; Flashes when LOW Alarm is Tripped
8	Flow Control Valve	Controls the Flowrate through the Unit
9	LOW Alarm Adjustment Knob	Used to Position LO Alarm Set Point
10	Power Jack	Used to Supply Power to the Optalarm™

Figure 2 – Functions of Components

SPECIFICATIONS

Dimensions

Height	9.81 in. (249.2) mm
Width	2.03 in. (51.6) mm
Depth	1.88 in. (47.8) mm

Flow Ranges Available

Air	50 CCM to 134 LPM
Water	0.6 CCM to 4.25 LPM

Meter Accuracy

Standard	$\pm 3\%$ of full scale @ STP
Optional	$\pm 1\%$ of full scale @ any calibrated conditions

Repeatability of Alarm

- 0.5 % Full Scale

Environmental Conditions

Operating Temperature	42 to 158 °F (5.6 to 70 °C)
Storage Temperature	32 to 158 °F (0 to 70 °C)
Humidity Range	35% to 85% relative humidity; non-condensing

Contact Ratings

Maximum Voltage	175 VDC
Maximum Switching Current	250 mA
Maximum Carrying Current	1 Amp
Maximum Rating	5 VA

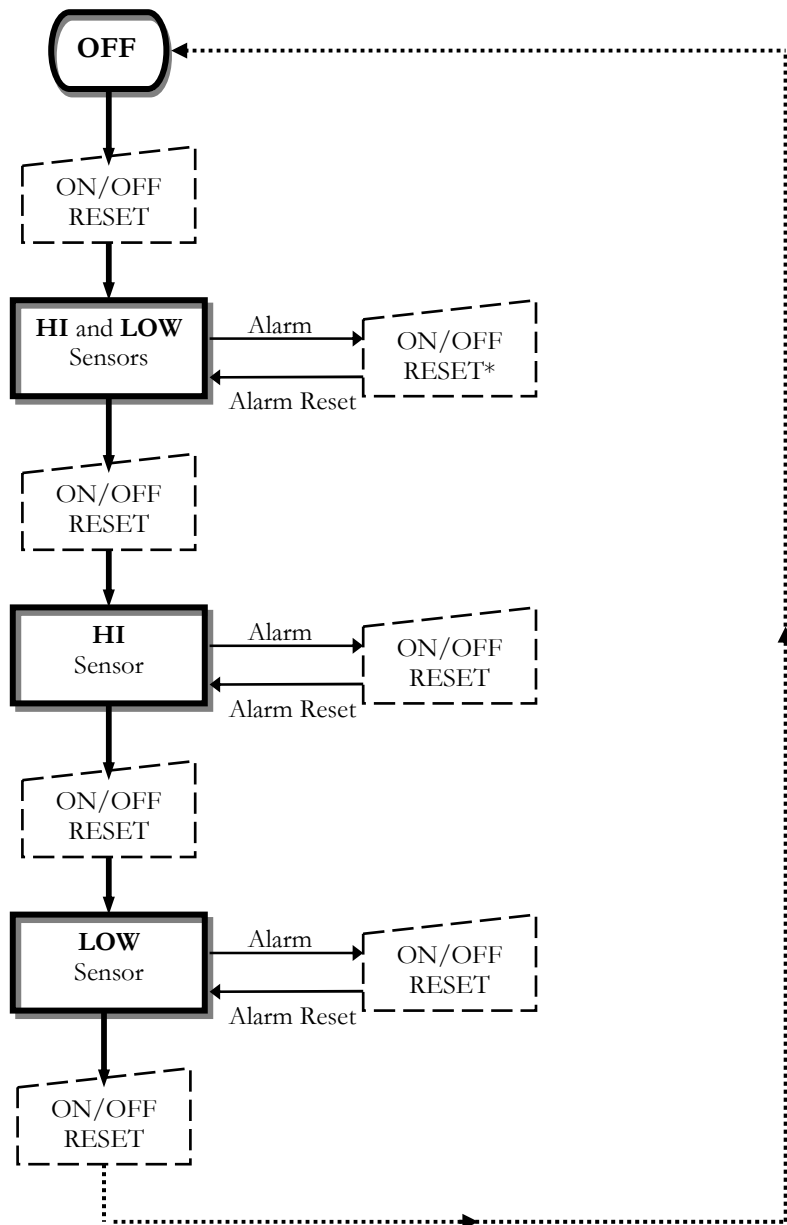

* **NOTE:** If *both* HI and LOW Alarms have been tripped, the ON/OFF RESET button must be depressed *twice* to reset both alarms.

Figure 3: Indexing Sequence for “ON/OFF RESET Button”

FEATURES

Operation Modes

Key Instruments Optalarm™ is capable of operating in three different modes. Depressing the ON/OFF – RESET button will index the unit sequentially through its modes. (Reference Figure 3: Indexing Sequence for “ON/OFF RESET Button”)

- The first mode is the HI/LOW Mode. In this mode, both sensors are actively scanning for an interruption by the float. This mode of operation can be used when the flowrate must be maintained between two limits.
 - An additional application for this mode is a two-tier monitoring mode. As described above, both sensors are actively scanning for an interruption by the float; however, the float is located either above or below both sensors in this method of operation. For example, if the flowrate drops below the Upper Sensor, the first alarm will sound. This method of operation, used in conjunction with the 8 Pin Mini-DIN connector will warn the operator that the flowrate has fallen to a potentially problematic level. If the flowrate continues to decrease to an unacceptable level, the Alarm for the Lower Sensor will sound and the 8 Pin Mini-DIN Connector can be used to pause the process or start an alternate process.
- The second mode is the HI Mode. In this mode, the Upper Sensor is the only sensor that is actively scanning for an interruption by the float. This mode can be used to monitor systems that require the flowrate to stay below a maximum preset level.
- The third mode is the LOW Mode. In this mode, the Lower Sensor is the only sensor that is actively scanning for an interruption by the float. This mode can be used to monitor systems that require the flowrate to stay above a minimum preset level.

Sensor Status

	HI LED	LOW LED	Sensor Status
1	On	On	Both Upper and Lower Sensors are actively scanning for an interruption by the float.
2	On	Off	Upper Sensor is actively scanning for an interruption by the float.
3	Off	On	Lower Sensor is actively scanning for an interruption by the float.
4	Off	Off	Unit is not on.

Alarm Modes

- The Optalarm™ is equipped with a 90-dB (Maximum) audible signal that sounds when the flow deviates from the preset range. The two indicator LEDs and the audible signal produce four distinctive alarm conditions.

	HI LED	LOW LED	Audible Signal	Alarm Condition
1	Off	Flashing	Beeping at Slow Rate	Float has crossed LOW Limit Level
2	Flashing	Off	Beeping at Fast Rate	Float has crossed HI Limit Level
3	Flashing	Flashing	Beeping at Fast Rate	Float has crossed both Limit Levels
4	On	On	Continuously On	Interference has been detected

Alarm Outputs

- This feature has been designed to work in conjunction with the flashing LEDs and audible signals. There is one normally open (NO) and one normally closed (NC) contact for each alarm condition for applications that require a dry contact to drive relatively low-voltage and low-current load selected options such as relays, solenoids, LEDs, etc. While in operation, relays are in an energized state; when an alarm condition or power failure occurs, the relays return to their unenergized (normal) position.

Millimeter Reference Scales

- The meters are supplied with flow curves for air and water. On request, flow curves for other gases or liquids can be supplied, and direct read scales are available on a special order basis.
- To ensure accurate flowrate readings on all flowmeters with millimeter scales, the following should be verified: the tube part number and revision level printed on the top of the tube (for example, 1G04 R4) should correspond with the tube number and revision level on the Flow Curve Data Sheet. The gas or liquid flowing through the meter and the float material should also match the specification on the Flow Curve Data Sheet.

OPERATION

- Adjust the **HI Alarm Set Pointer** by turning the **HI Alarm Adjustment Knob** to the desired high flow limit to be monitored.
- Adjust the **Low Alarm Set Pointer** by turning the **Low Alarm Adjustment Knob** to the desired low flow limit to be monitored.
- Adjust the **Valve** so the **ball float** rises to the pre-determined set-point.
- Supply the Optalarm™ with Power, either by using the 8 pin Mini-DIN or by using the supplied power jack.
- Turn the Optalarm™ on by pressing the **On/Off Reset** button once. Both **upper** and **lower LEDs** will be on steady, which indicates that the unit is in **HI/LOW** mode. Pressing the **On/Off Reset** button a second time will turn the **lower LED** off, which indicates that the unit is set in **HI mode**. Pressing the **On/Off Reset button** a third time will light only the **lower LED**, which indicates that the unit is in **LOW mode**. Pressing the **On/Off Reset button** a fourth time will turn the unit off.
- If the float crosses a limit level, the appropriate **LED** will start flashing and the audio alarm will start sounding. Pressing the **On/Off Reset button** will reset that alarm.
- If both limits are crossed, both **LEDs** will flash and the alarm will sound at a high rate. Press the **On/Off Reset button** twice to silence the alarms.
- If during operation, the audio alarm sounds a steady tone, the unit has detected interference. Remove the source of the interference, reset the alarm and the unit will return to normal operation.