INSTALLATION & OPERATION INSTRUCTIONS OF GR8000
FOR 65MM AND 150MM GLASS TUBE FLOWMETER

Standard glass tube flowmeters are available in various ranges and configurations. The meters have 65 millimeter and 150 millimeter reference scales, and are supplied with flow curves for air and water. At your request, flow curves for other gases and liquids can be supplied, and direct read scales are available on a special order basis.

UNPACKING

Precautions have been taken to prevent any damage from occurring during shipment. However, if the meter is received damaged, *report it to the carrier immediately*. Verify that you have the model and flow range that you require.

MILLIMETER REFERENCE SCALES

To ensure accurate flowrate readings on all flowmeters with millimeter reference scales, the following should be verified: the tube part number and revision level printed on the top of the tube (for example, 1G04 R4) should correspond with the tube number and revision level on the Flow Curve Data Sheet. The gas or liquid flowing through the meter and the float material should also match the specification on the Flow Curve Data Sheet.

ACHIEVING ACCURATE FLOWRATES

To obtain an accurate flowrate, the float must be read from the center of the ball. Additionally, the flowmeter should be installed in a manner, which minimizes both external vibrations and internal flow variations. Special care should be taken so that the connections to the meter's inlet and outlet fittings do not overly restrict the liquid or gas flow being metered. This could result in a reduced flow volume, preventing the meter from reaching its maximum flowrate. Furthermore, internal pressures could be affected, which can cause inaccurate flow readings. Prior to use, any air/gas trapped in the meter should be slowly purged and the meter should be checked for leaks.

INSTALLATION

The flowmeter is capable of being panel mounted or mounted on a leveling tripod base. In order to mount the meter on a panel, two clearance holes must be drilled. (Refer to Figure 1 for the correct locations of the 19/32" diameter clearance holes.) The meter is secured to the panel using the pal nuts, which are supplied with the meter. The meter can also be mounted on an optional leveling tripod base for freestanding use. The meter is supplied with 1/8" FNPT non-rotating fittings. When installing the fittings the meter, place the appropriate size wrench on the hex to prevent the inlet and outlet fittings from rotating. (Use pipe thread sealant or Teflon® tape to achieve a positive seal.) **When installing the 1/8-27 MNPT fittings into the meter, torque to 60 in-lbs. maximum.** Failure to hold the inlet/outlet fittings or over-torquing the fittings could cause serious damage to the fittings or the meter backplate.

CLEANING

Occasional cleaning may be required if dirt appears in the flow tube or if float movement becomes restricted. The tube assembly can be removed from the meter frame for cleaning or replacement of parts without removing the meter from the process line. The tube and float should be cleaned with a mild liquid detergent and a soft brush or swab. All pieces should be rinsed/flushed with clean water, and dried thoroughly with clean dry air or nitrogen.

DISASSEMBLY

If the meter is to be disassembled for any reason; be sure to first bleed off any pressure in the meter. With a 5/32" Allen wrench, turn the jackscrew counter-clockwise until it reaches a stop. Gently remove the tube assembly from the meter frame. Remove the lens caps and shield. Remove the top float stop and the float from the top of the tube. Next, remove the bottom float stop from the bottom of the tube. To remove a control valve, turn counter-clockwise with a 1/2" wrench.

REASSEMBLY

Check to make sure that all parts are clean and dry. Install the bottom float stop into the bottom of the flow tube. Install the ball float and the top float stop from the top of the tube. Install the bottom lens caps on the tube. Insert the tube in the lens shield and install the top lens cap. Check the top and bottom gaskets and replace, if necessary. Carefully slide the tube assembly back into the meter, making sure that it is properly aligned with the scale facing forward. Tighten the jackscrew by turning clockwise until the gaskets make contact with the tube. **Carefully torque to 1-1 3/4 in-lbs. to achieve a positive seal. Do not over-tighten.** To replace a control valve, turn clockwise with a 1/2" open-end wrench. Close the valve and slowly pressurize the meter. Check for leaks before resuming operation.

If you have any questions regarding installation, maintenance or use of this flowmeter, please call Key Instrument's Customer Service Department at 1-800-356-7483.

CAUTION

THIS FLOWMETER IS DESIGNED FOR USE WITH NON-HAZARDOUS FLUIDS AT PRESSURES UP TO 200 PSI (13.8 BAR) AND TEMPERATURES UP TO 200 °F (93 °C). DO NOT USE HAZARDOUS FLUIDS AND DO NOT EXCEED TEMPERATURE OR PRESSURE LIMITS. USE WITH HAZARDOUS FLUIDS OR EXCEEDING THE PRESSURE AND TEMPERATURE LIMITS MAY CAUSE FAILURE THAT COULD RESULT IN INJURY.

SPECIFICATIONS	
ACCURACY:	± 5% Full Scale – 65 mm ± 3% Full Scale – 150 mm
FLOATS:	Black Glass Ball Float Sapphire Ball Float Stainless Steel Ball Float Tungsten Carbide Float Tantalum Float
FRAME BACKPLATE:	Anodized Aluminum
END BLOCKS AND ELASTOMERS:	Aluminum with Buna-N Brass with Buna-N Stainless Steel with Viton®
FITTINGS:	1/8-27 FNPT Fittings
GLASS TUBE:	Precision Formed Borosilicate
MAXIMUM TEMPERATURE:	200°F (93 °C)
MAXIMUM PRESSURE:	200 PSI (13.8 Bar)

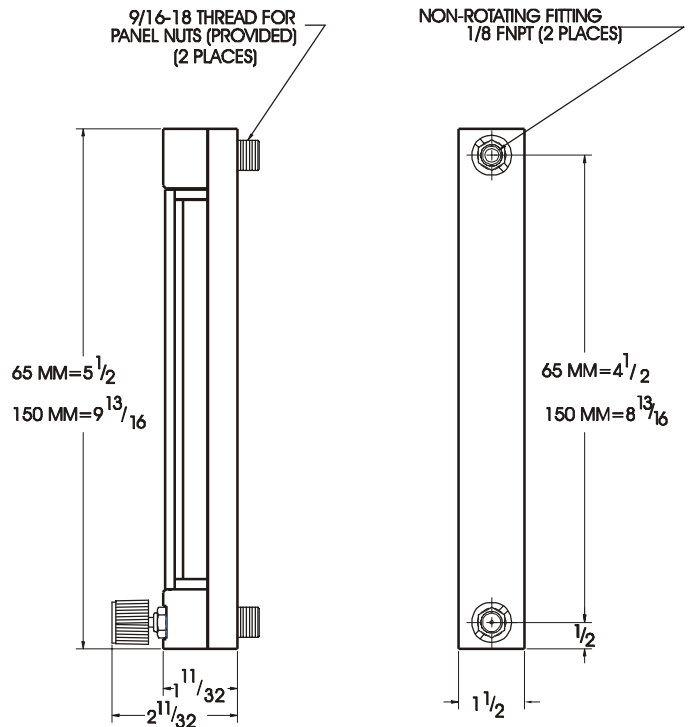

FIGURE 1

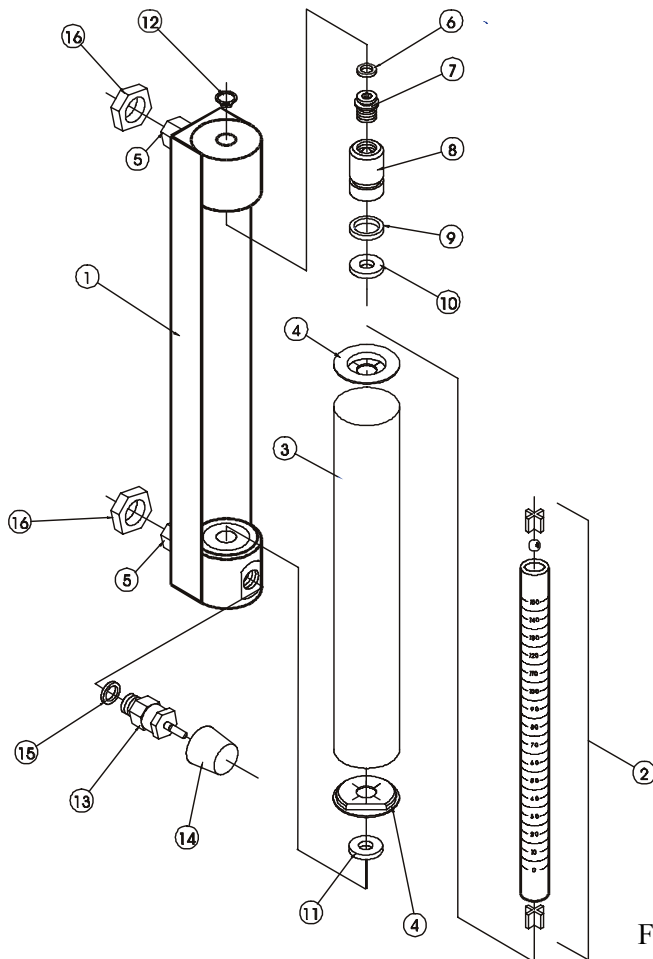

FIGURE 2

Number	Description
1	Frame Assembly
2	Tube Assembly
3	Lens
4	Lens End Cap(s)
5	Fitting
6	Jack Screw O-ring
7	Jack Screw
8	Jack Plug
9	Jack Plug O-ring
10	Top Gasket
11	Bottom Gasket
12	Retaining Clip
13	Optional Valve
14	Valve Knob
15	Valve O-ring
16	Panel Nuts

CONTINUED PRODUCT IMPROVEMENT MAY RESULT IN SPECIFICATION REVISIONS
 WHEN ORDERING PARTS PLEASE INCLUDE PART DESCRIPTION, ITEM NUMBER AND TYPE OF MATERIAL REQUIRED.